

# ED8400 Series

## Vertical Rod Exit Devices (Not Reversible)

# INSTALLATION INSTRUCTIONS FOR WOOD & METAL DOORS

**BEFORE INSTALLING:** Check to be sure the Exit Device is the proper hand for your door.

### HOW TO DETERMINE HAND OF DOOR

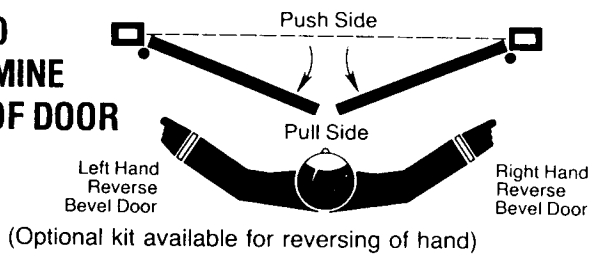

## STEP 1 MARK CENTER LINES:

Mark Center Lines on INSIDE of door. Establish the horizontal center line of the device by drawing a line across the door  $40\frac{5}{16}$ " above floor line. Establish the top and bottom rod backset center line by drawing a vertical line from the top to bottom of the door measuring from the LOW SIDE of the DOOR BEVEL.

(See illustration below)

### INSIDE OF LHRB DOOR IS ILLUSTRATED

LOW SIDE OF DOOR BEVEL

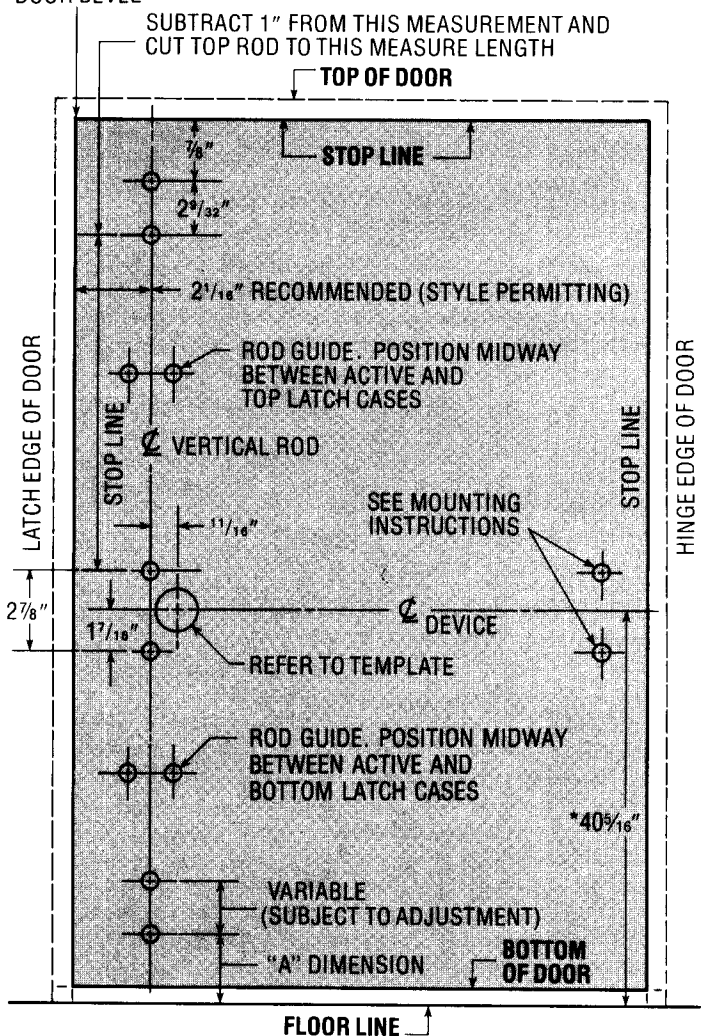

\*Regularly furnished unless otherwise ordered.

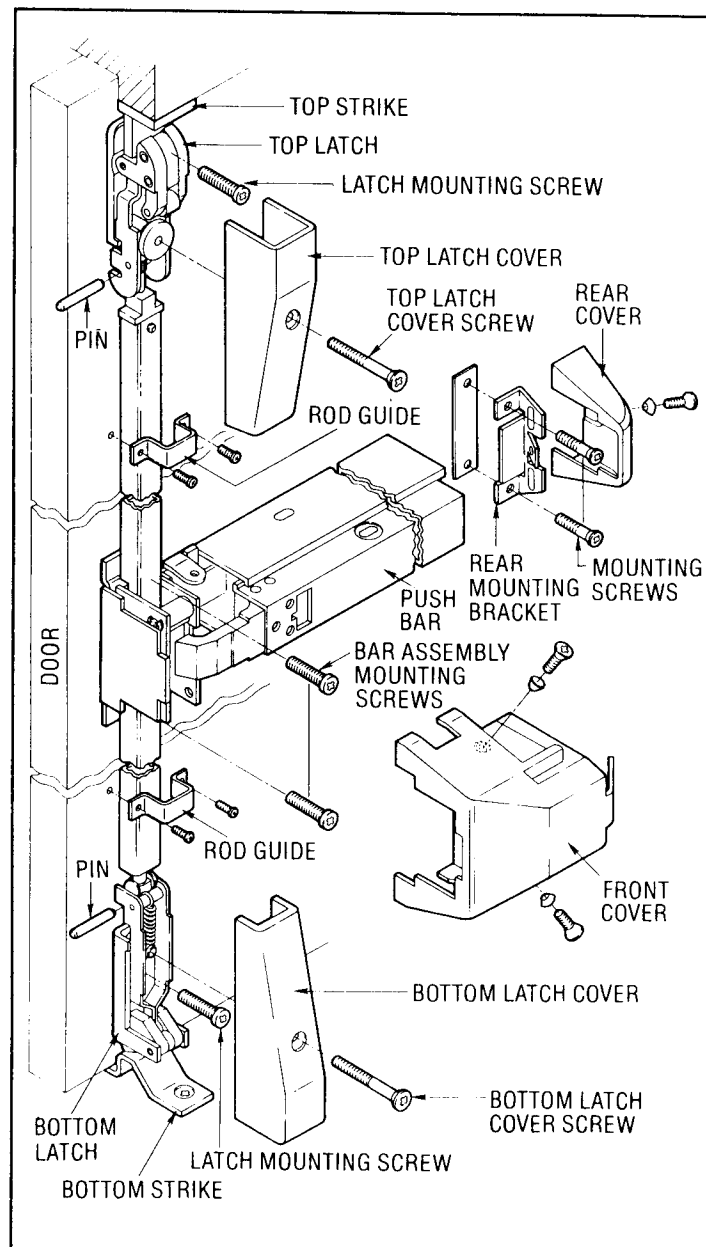

"A" DIMENSION	INSTALLATION
$1\frac{7}{8}$ "	Surface Strike
$1\frac{5}{16}$ "	Flush Strike

## STEP 2 SPOT AND DRILL TEMPLATE HOLES:

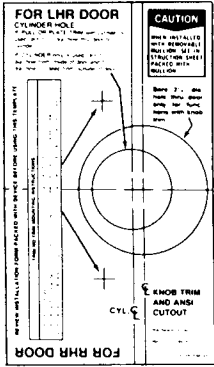

Using Template furnished, spot and drill Mounting Holes for Trim (if furnished), and Device. Be sure the Template is aligned with horizontal and vertical center lines on the **INSIDE OF DOOR**.

### NOTE:

If your door has Cylindrical Lock cut-out for ANSI A115.2 and A115.3 ANSI prep doors:

- Extend horizontal and vertical center lines of ANSI cut-out as shown at right.
- Align ANSI cut-out center lines on template with center lines on door. Spot and drill holes as needed.

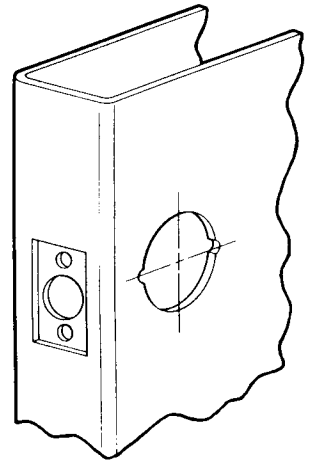

## STEP 3 INSTALL TRIM:

MOUNT CYLINDER HORIZONTALLY AS SHOWN BELOW. CUT OFF LENGTH OF CYL. CONNECTING BAR SO THAT  $\frac{3}{16}$ " PROJECTS BEYOND INSIDE FACE OF DOOR.

**CAUTION: REFER TO TEMPLATE PACKED WITH TRIM BEFORE PROCEEDING WITH STEP 3.**

Follow illustration below for Trim Installation procedure.

### PULL TRIM

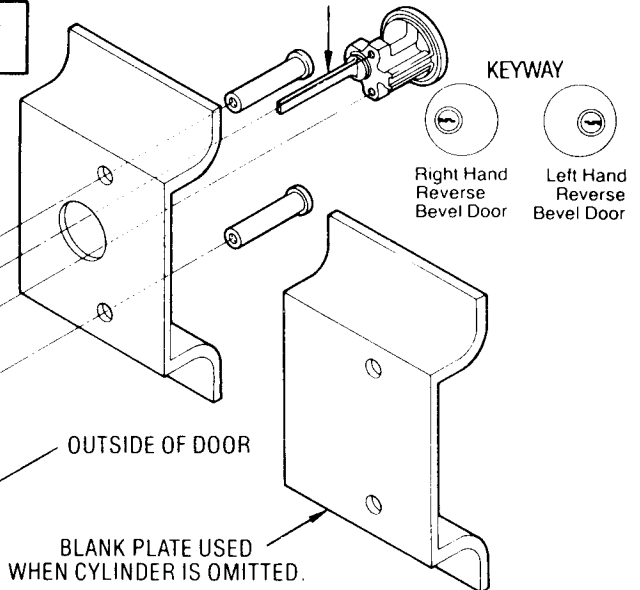
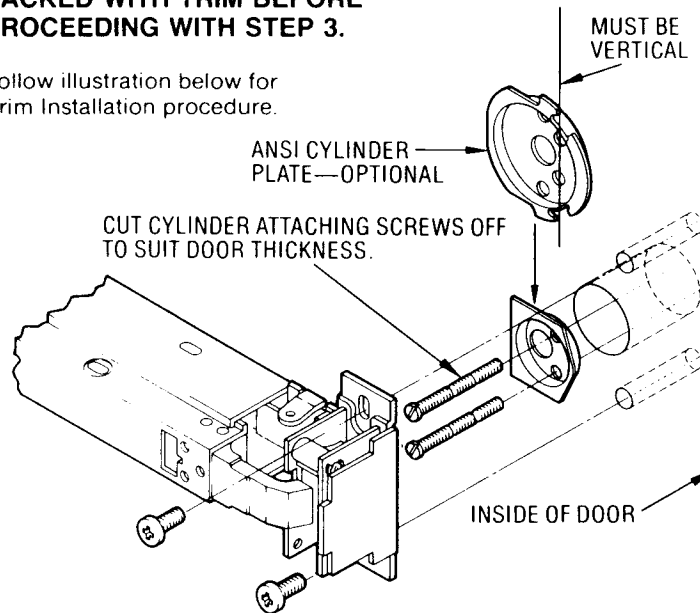

CUT OFF LENGTH OF CYLINDER CONNECTING BAR SO THAT  $\frac{3}{16}$ " PROJECTS BEYOND INSIDE FACE OF DOOR.

MOUNT KEYWAY IN KNOB VERTICALLY AS SHOWN

### KNOB TRIM

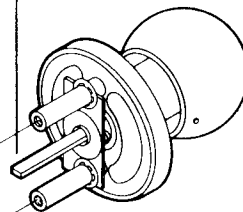
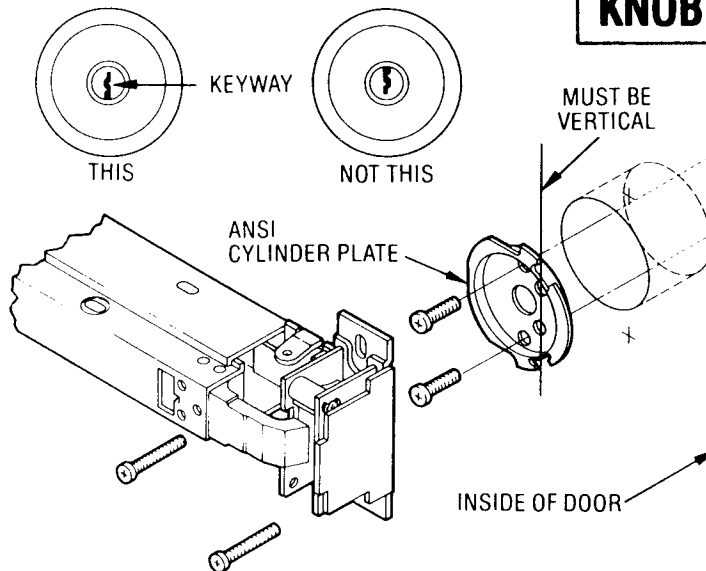

OUTSIDE OF DOOR

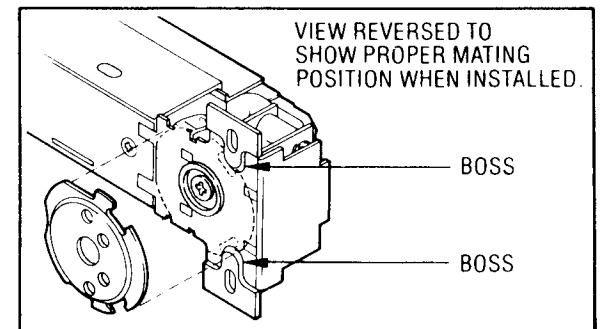

**CAUTION: WHEN USING THE ANSI CYLINDER PLATE BE SURE THE BOSSES ON THE LATCH ASSEMBLY FIT INTO THE CUTOUTS ON THE CYLINDER PLATE SO THAT THE LATCH ASSEMBLY LIES FLAT ON THE**

## STEP 4 LOCATE LATCHES:

Locate Top and Bottom Latch. Mark for later installation. (See illustration on Page 1 for dimensions and locations.)

## STEP 5 CUT PUSH BAR:

Follow illustration below. (IF BAR DOES NOT REQUIRE CUTTING, PROCEED TO NEXT STEP.)

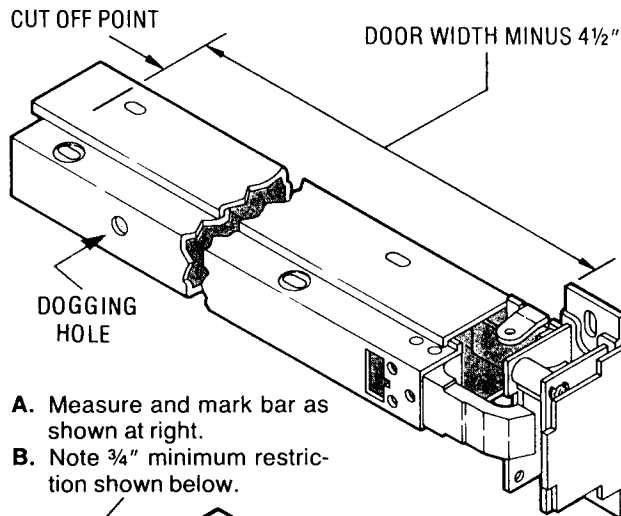

- Measure and mark bar as shown at right.
- Note 3/4" minimum restriction shown below.

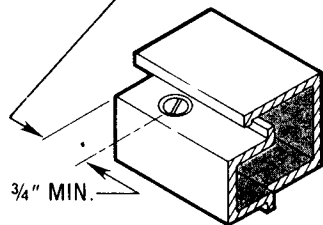

- Fully depress bar and cut off square on mark.

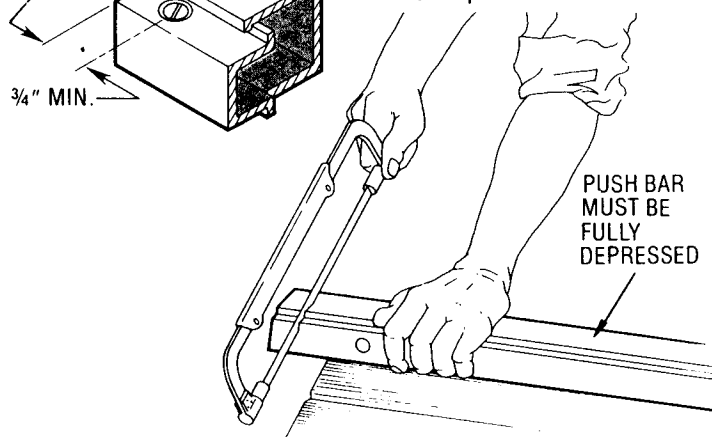

## STEP 6 MOUNT DEVICE:

Attach Bar Assembly to door, but do not tighten screws. Assemble Rear Mounting Bracket to Push Bar (see nesting arrangement in exploded view on Page 1). Use Rear Mounting Bracket as a template to spot holes for Mounting Screws. Push Bar should be level. Drill Screw holes and attach Rear Mounting Bracket and Plate to door. Secure Front Plate Screws.

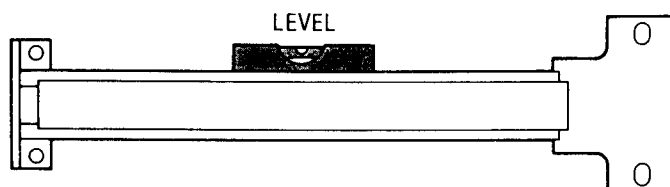

## STEP 7 INSTALL STRIKES:

Close door. Align center of Strike with Vertical Backset center line on door and install top and bottom Strikes.

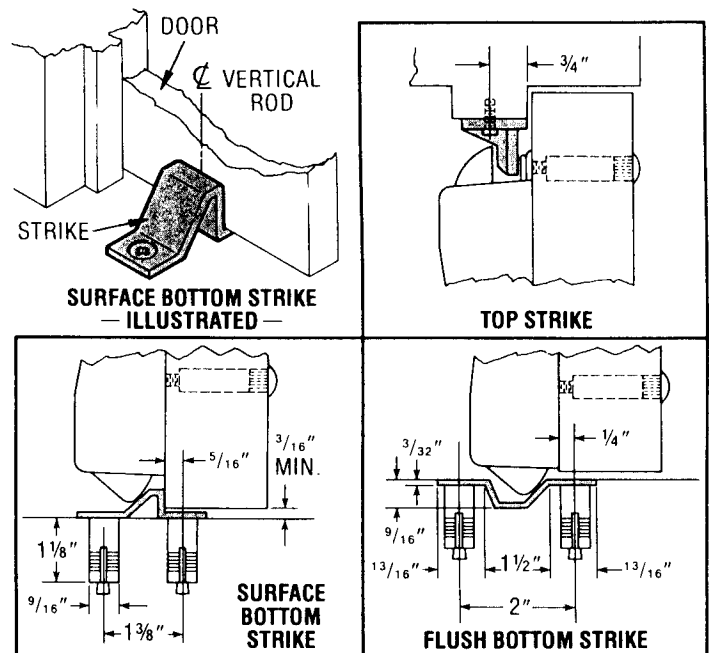

## STEP 8 MOUNT BOTTOM LATCH:

Insert Bottom Latch Screw through slot in Latch Frame into bottom hole. Do not tighten. Lift up Slide Assembly and fit the Spring Loop over the stump on the latch frame. Position Latch Frame so that Latch engages strike. Now tighten bottom screw.

Drill a hole for the Cover Screw, using the hole in the Slide Assembly at top as guide. Spot with 1/4" drill. Drill through with #3 drill for self-tapping screw.

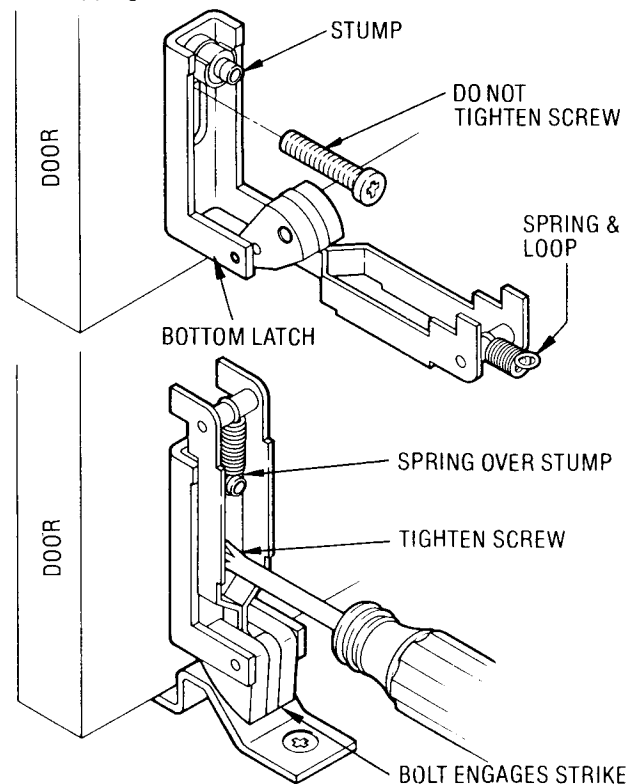

## STEP 9 MOUNT TOP LATCH:

Retract the latch by pushing up on slide and fasten Latch Assembly with screws as illustrated. Be sure to draw the screw up tight. Drill hole for the cover screw, using the hole in the Slide Assembly at bottom as guide.

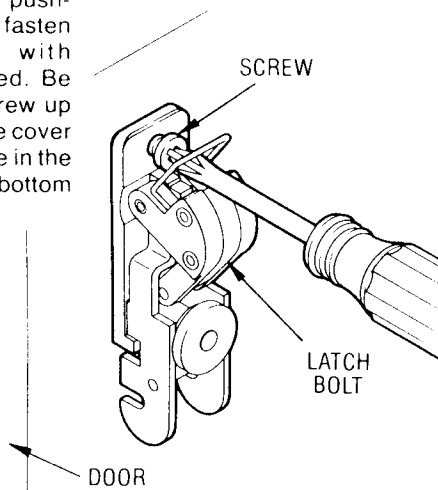

## STEP 10 TOP ROD ASSEMBLY:

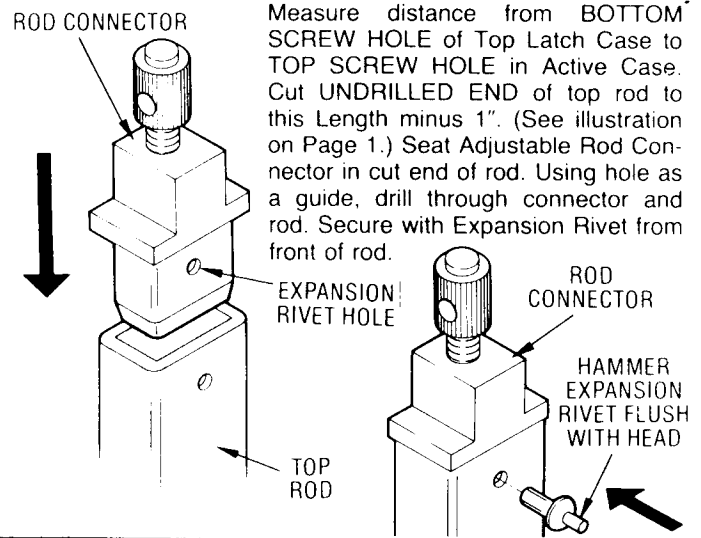

Measure distance from BOTTOM SCREW HOLE of Top Latch Case to TOP SCREW HOLE in Active Case. Cut UNDRILLED END of top rod to this Length minus 1". (See illustration on Page 1.) Seat Adjustable Rod Connector in cut end of rod. Using hole as a guide, drill through connector and rod. Secure with Expansion Rivet from front of rod.

## STEP 11 INSTALL TOP ROD AND ADJUST TOP LATCH:

Attach Top Rod to Bar Assembly by slipping hole over Stump and secure Rod by means of "E" Ring. Shut door. Turn Adjustable Rod Connector until head touches underside of latch slide. Insert pin. Depress bar, if top latch does not retract completely, remove pin and turn connector to adjust length. Repeat until Latch Bolt just disengages.

**CAUTION: MAKE CERTAIN "E" RING ENGAGES SLOT IN STUMP.**

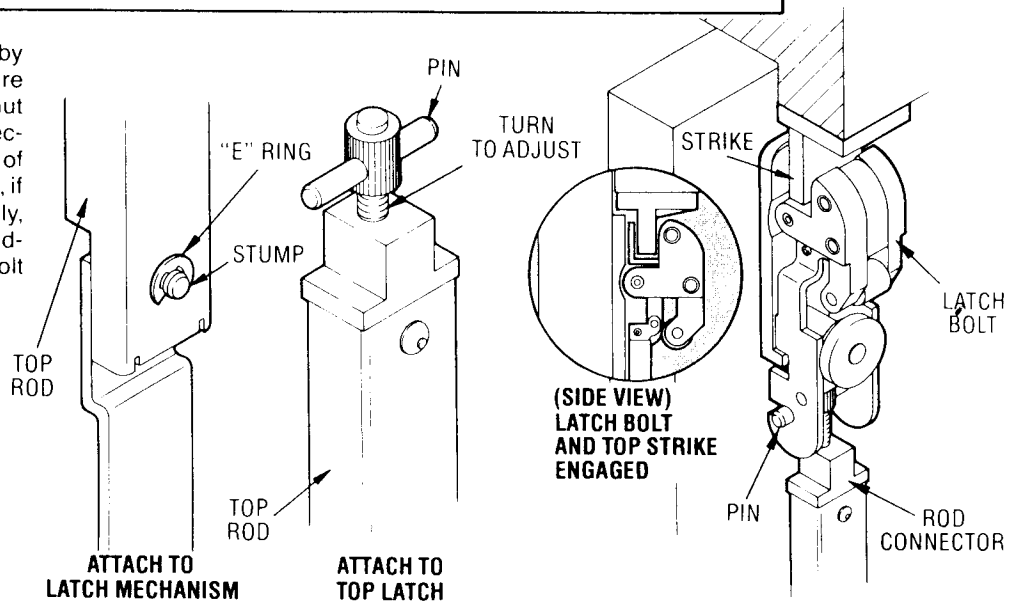

## STEP 12 INSTALL AND ADJUST BOTTOM ROD:

Attach Bottom Rod to Bar Assembly by slipping hole over Stump and secure Rod by means of "E" Ring. Shut door. Dog down Active Case. Insert pin into Rod Connector. Turn Adjustable Rod Connector by turning clockwise or counter clockwise until Latch Bolt just clears Strike. Undog Device.

**CAUTION: MAKE CERTAIN "E" RING ENGAGES SLOT IN STUMP.**

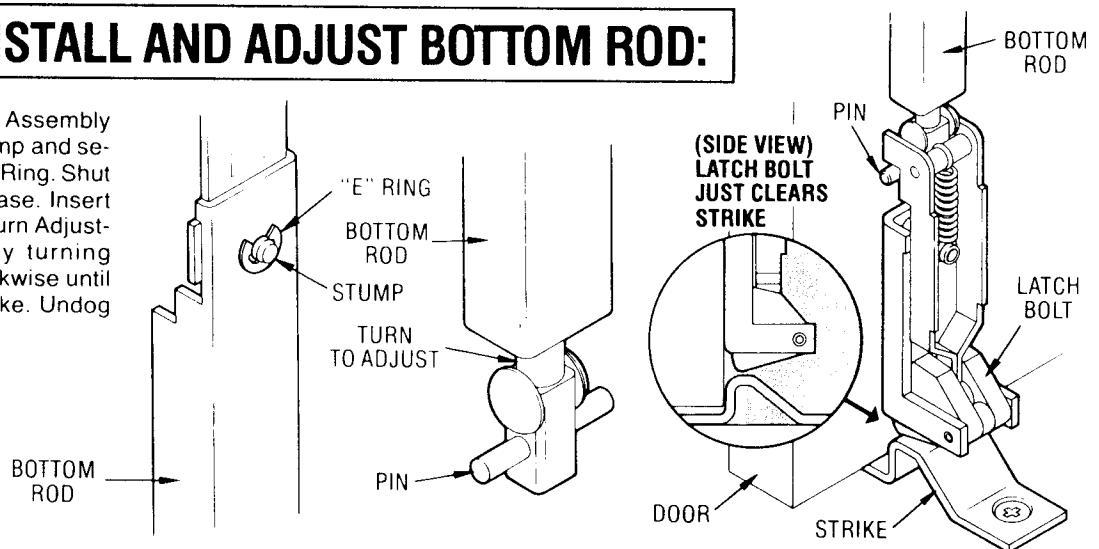

ATTACH TO LATCH MECHANISM

ATTACH TO BOTTOM LATCH

BOLT JUST CLEARS STRIKE

## STEP 13 MOUNT TOP AND BOTTOM LATCH COVERS:

**Bottom Cover**—Position above Bottom Latch Frame align with hole in slide assembly at bottom. Secure with furnished screw.

**Top Cover**—Position and secure with screw through bottom hole in Top Latch Frame.

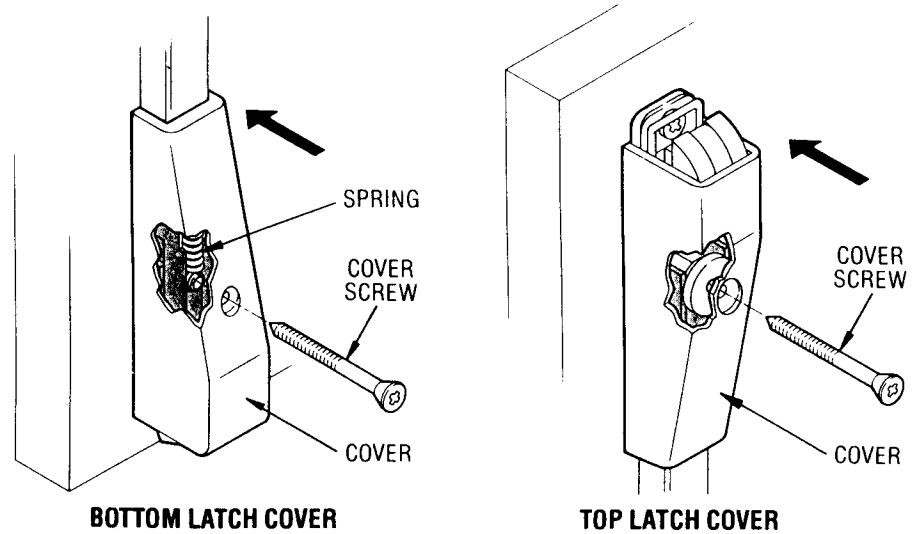

## STEP 14 TEST PUSH BAR AND DOGGING OPERATIONS:

The latches should engage the strikes when the door is closed. If the door can be pushed open without depressing the push bar the top rod connector has been over adjusted. Remove cover. Adjust connector as needed. Replace cover.

The top and bottom latches should disengage from the strikes freely when the push bar is depressed or dogged down. If they do not disengage, remove the covers and adjust the connectors as needed. Replace the covers. Retest for proper operation.

### DEVICE ONLY

Top and bottom latch bolts are retracted by the push bar inside.

### DEVICE WITH TRIM

Top and bottom latch bolts are retracted by the push bar inside and the key or knob outside.

**To lock knob:** Insert key in cylinder and turn counterclockwise as far as key will turn. Then return key to its vertical position and withdraw key.

**To unlock knob:** Insert key in cylinder and turn clockwise as far as key will turn (the latches will retract during this procedure). Then return key to its vertical position and withdraw key.

**DOGGING:** Depress push bar. Insert dogging wrench and turn clockwise 90°. The push bar will remain depressed and the latches will remain retracted.

## STEP 15 MOUNT ROD GUIDES:

Place Guides over the rod. (One above the Bar Assembly and One below the Bar.) Be sure the Guides will not bind against the rods. Use holes in the Guides to spot screw location. Drill holes and secure the Guides to the door.

*Check to be certain the rods move freely.*

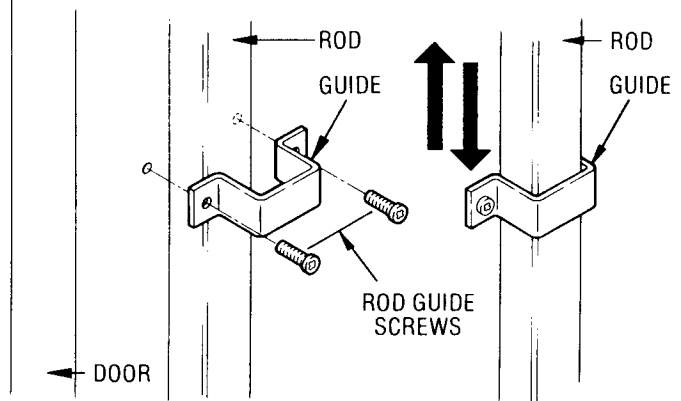

**RODS MUST MOVE FREELY—UP AND DOWN**

# TO REMOVE AND REINSTALL CYLINDER IN KNOB:

**REMOVE KNOB:**

1. Insert key in cylinder and turn 90° clockwise.
2. Insert knob removing tool into the hole in the knob and depress the knob catch button.
3. While knob catch button is depressed pull knob off.

(The knob catch button will be in one of these positions).

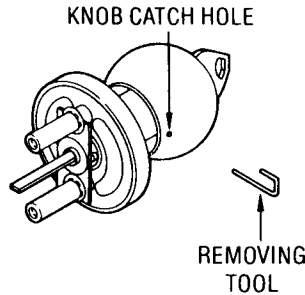
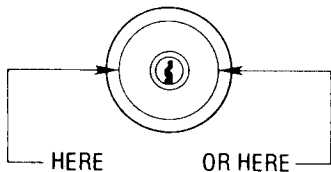

**REMOVE CYLINDER FROM KNOB:**

1. Remove sleeve
2. Remove key
3. Slide cylinder out of knob.

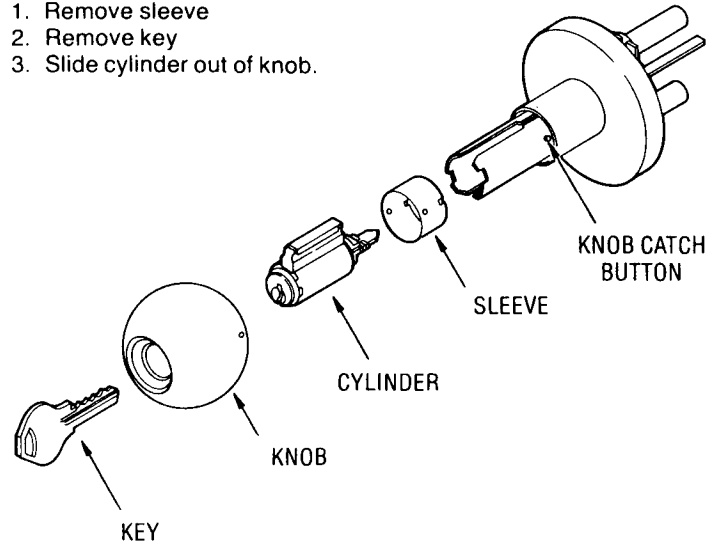

**REINSTALL CYLINDER IN KNOB:**

1. Slide cylinder into knob.
2. Replace sleeve.

**REINSTALL KNOB:**

1. With key inserted part way into cylinder slide knob onto knob shank.
2. Depress knob catch button and push knob on to the knob shank as far as it will go.
3. Insert key completely into the cylinder and turn the key while

- pushing on the knob until it engages the knob catch button.
4. Return key to its vertical position and remove it.
5. Pull on the knob to be certain it is properly engaged to the knob catch button.

SCREW CHART		
Item	Qty.	Fastener
Top strike	2	12-24 x 1/2" Lg. pan head machine screw or #12 x 1 1/4" Lg. round head wood screws
Top and bottom latch	2	1/4-20 x 3/4" Lg. binding head machine screws and sex nuts P/N 101F74 or #14 x 3/4" Lg. pan head wood screws
Top latch cover	1	1/4-20 x 1 1/8" Lg. oval head machine screw and sex nut P/N 101F74 or #14 x 2 1/4" Lg. oval head wood screw
Top and bottom rod guides	4	#8 x 3/4" Lg. round head tapping screws type "A"
Front plate assembly and rear bracket	4	12-24 x 3/4" Lg. pan head machine screw and sex nuts P/N 376F37 or #12 x 1 1/4" Lg. pan head tapping screws type "A"
Bottom Latch Cover	1	1/4-20 x 2" Lg. oval head tapping screw type "F" or #14 x 2 1/4" Lg. oval head wood screw.
Bottom Strike	2	1/4-20 x 5/8" Lg. flat head machine screws and anchors P/N 361F30 or #14 x 1 1/4" flat head wood screws

Drill sizes for screws and sex nuts cannot be recommended because various factors, such as type of door and frame construction, thickness and type of metal, etc. can affect the final hole diameter and resulting holding strength of the fastener



In U.S.:  
Corbin Russwin, Inc.  
225 Episcopal Road  
Berlin, CT 06037 USA  
Phone: 860-225-7411 Fax: 860-828-7266

In Canada:  
Yale-Corbin Canada LTD.  
3160 Orlando Drive  
Mississauga, Ontario, Canada L4V1R5  
Phone: 905-672-6220 Fax: 905-672-9022