

# Installation Instructions

As Easy As **A**—**B**—**C**—→**J**

## Universal Door Closers Slide Track Application (100° Maximum Door Swing) A1 - H.O. Bumper Stop

### Hinge (Pull) Side Door Application

**DC8230 Series**  
Multi-Size 1 thru 6

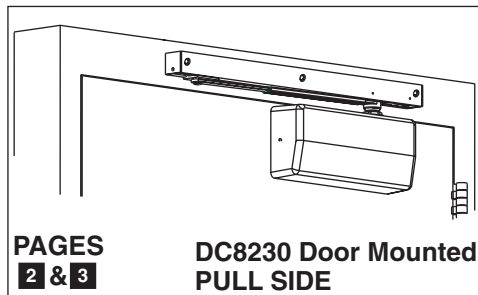

### Hinge (Push) Side Door Application

**DC8240 Series**  
Half-Size 1 thru 6

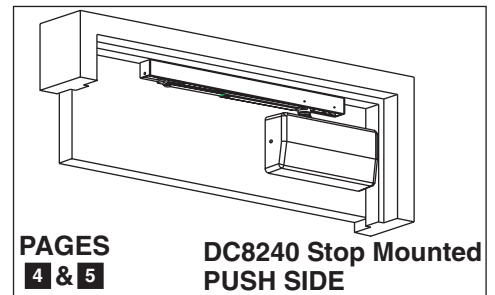

### IMPORTANT:

- An improperly installed or incorrectly adjusted door closer may cause **property damage** or **personal injury**; and will void product warranty.
- To avoid personal injury, **DO NOT DISASSEMBLE THIS DOOR CLOSER BODY.**
- Door closers must be securely fastened to a properly reinforced door and frame with fasteners provided.
- Door closers with the "A1" HOLD OPEN TRACK option are not permitted to be installed in fire door assemblies.

### BEFORE INSTALLING:



- The Americans with Disabilities Act (ADA) requires that doors having door closers have an opening force not to exceed 5 lbf.
- The door closer's power size adjustment feature may require adjustment to its lowest setting to comply with ADA opening force guidelines.
- ADA compliant closers are: DC8230 & DC8240.

Size of Door & Door Closer					
Type of Installation	Interior	Exterior In-swinging	Exterior Out-swinging	Recommended Closer Size	**Max. Opening Force lbs/f
PULL SIDE Mounting	2'6"	—	—	1	8
	3'0"	2'6"	—	2	14
	3'6"	3'0"	—	3	16
	4'0"	3'6"	—	4	22
		4'0"	—	5	24
			4'0"	6	26
PUSH SIDE Mounting	2'6"	—	—	1	8
	3'0"	—	2'6"	2	14
	3'6"	—	3'0"	3	16
	4'0"	—	3'6"	4	22
		—	4'0"	5	24
				6	26

### TO DETERMINE HAND OF YOUR DOOR:

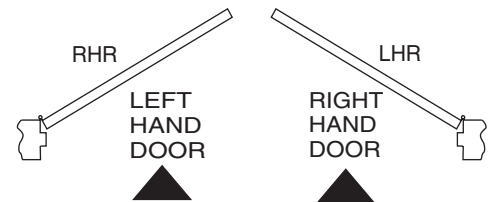

\*\*NOTE: These forces are for standard templating with bearing type hinges and do not account for pressure differentials and draft.

# DC8230 Pull Side Track Installation Instructions



This Page

Next Page (3)

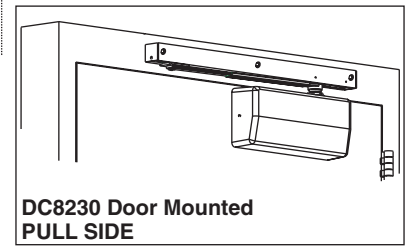

DC8230 Door Mounted PULL SIDE

## A Template

Mark Door and Jamb (for QUIK-INSTALL® bracket and track)

- Door will travel additional 5° to dead stop.
- Door hold open position adjustable from 85° to 120° of door opening.

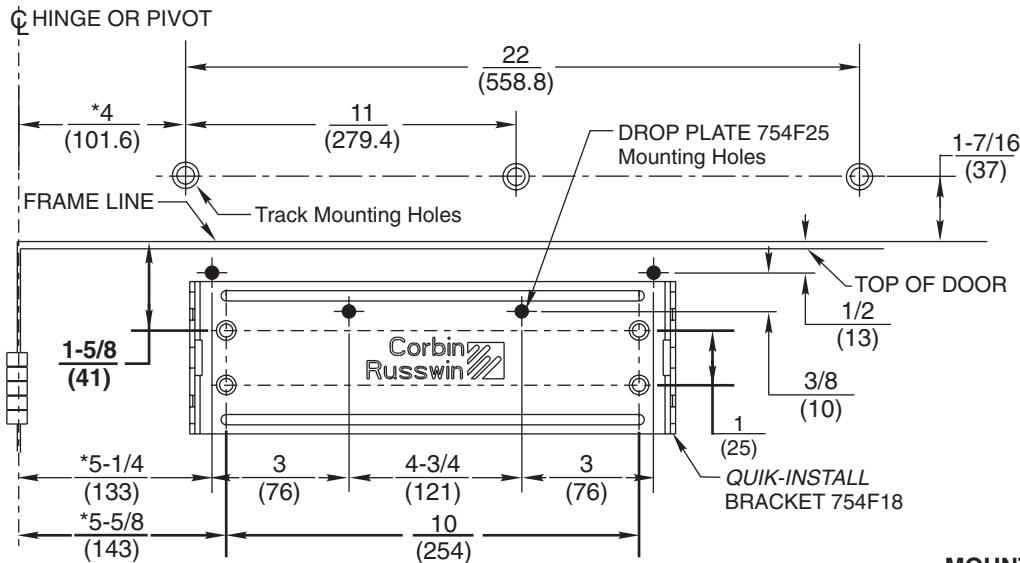

DOOR THICKNESS	SEX NUT LENGTH "L"
1-3/8 (35)	1-9/32 (33)
1-3/4 (44) & OVER	1-21/32 (42)

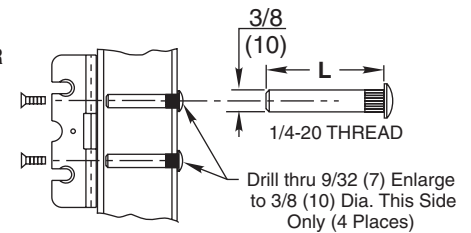

### MOUNTING SCREW SPECIFICATIONS ARM AND QUIK-INSTALL BRACKET

#12-14 self-drilling screw.  
1/8 (3) diameter pilot hole  
required for Wood  
Applications. } or { Sex nuts, furnished  
when ordered

#### NOTES:

- Check hand of door, see page 1.
- Right Hand Application Shown. Left Hand Opposite.
- Dimensions given in inches (mm). Do Not Scale Drawing.
- Closer must be installed in a true horizontal plane to ensure proper closer performance.
- Minimum clearance required over door: 2 (51).
- Minimum top rail: Without drop plate 3 (76), With drop plate 1-1/4 (32).

## B Install Closer Bracket

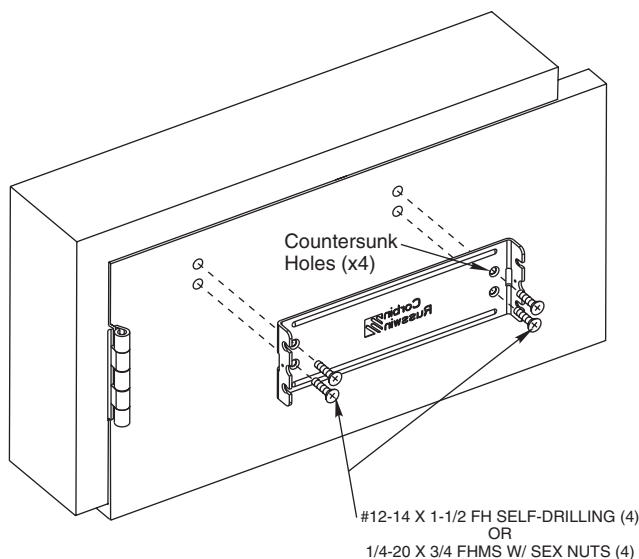

## C Mount Closer Body to QUIK-INSTALL Bracket

- Start the four mounting screws into the four closer mounting holes.
- Place the closer onto the QUIK-INSTALL bracket with the four mounting screws inserted into the four QUIK-INSTALL bracket slots.
- Tighten the four mounting screws to fasten the closer body to the QUIK-INSTALL bracket.

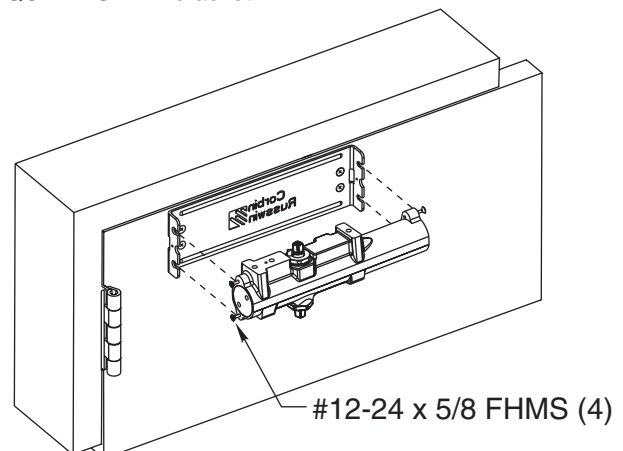

ASSA ABLOY

# DC8230 Pull Side Track Installation Instructions

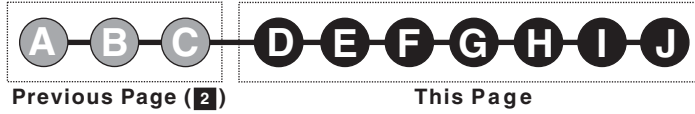

## D Attach Track to Frame

Spring buffer toward hinge edge of frame with open side facing down, fasten track assembly to frame.

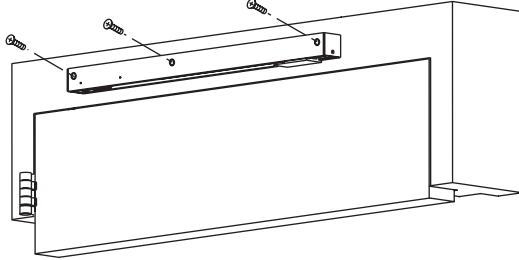

## E Adjust Arm to Shortest Length

Install 9/64" hex drive socket head screw from screw pack to the arm's shortest length as shown below.

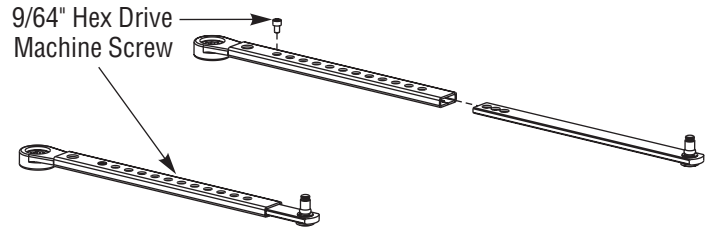

## F Place Slide Arm on Pinion Shaft

Place the slide arm and two washers on the pinion shaft, indexed as shown below. Secure the arm with the arm screw and washer as indicated.

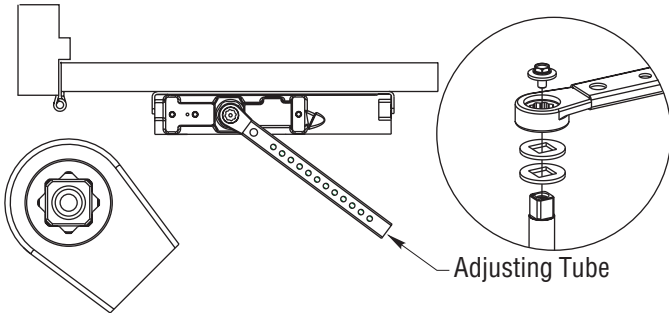

## G Insert Arm Stud into Slide Block

- 1) Insert the arm stud into the slide block in the track assembly.
- 2) Secure by pushing in on the retainer clip that extends from the slide block in the track, until it is flush with the slide block.

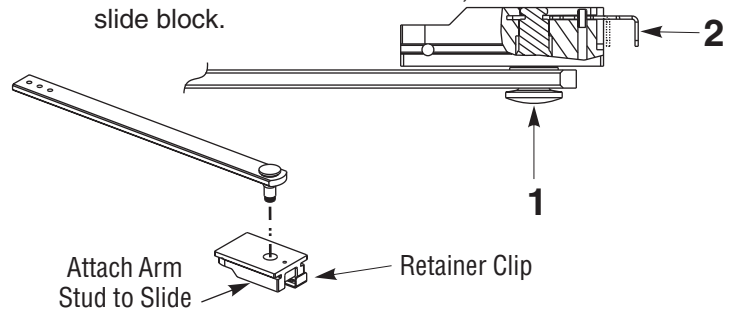

## H Adjusting Door Opening / Hold Open Angle

Open the door until the slider is against the cushioned stop or engaged in hold open (A1 Option only). Remove the 9/64" hex drive socket head screw from the arm. Open the door to the desired angle and install the hex-drive screw into the hole in the adjusting rod that is aligned with the hole in the adjusting tube.

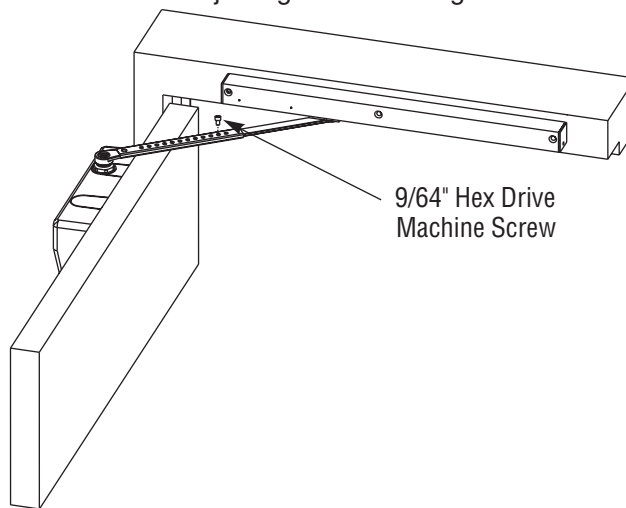

## I Adjust Closer: See Page 6.

## J ENGAGE/DISENGAGE Hold Open: (A1 Option Only) See Page 6.

**Corbin  
Russwin**

**ASSA ABLOY**

# DC8240 Push Side Track Installation Instructions



This Page

Next Page (5)

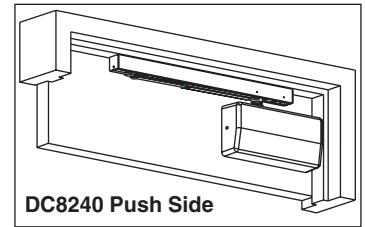

DC8240 Push Side

## A Template

### Mark Door and Stop (for QUIK-INSTALL® bracket and track)

- Door will travel additional 5° to dead stop.
- Door hold open position adjustable from 85° to 110° of door opening.

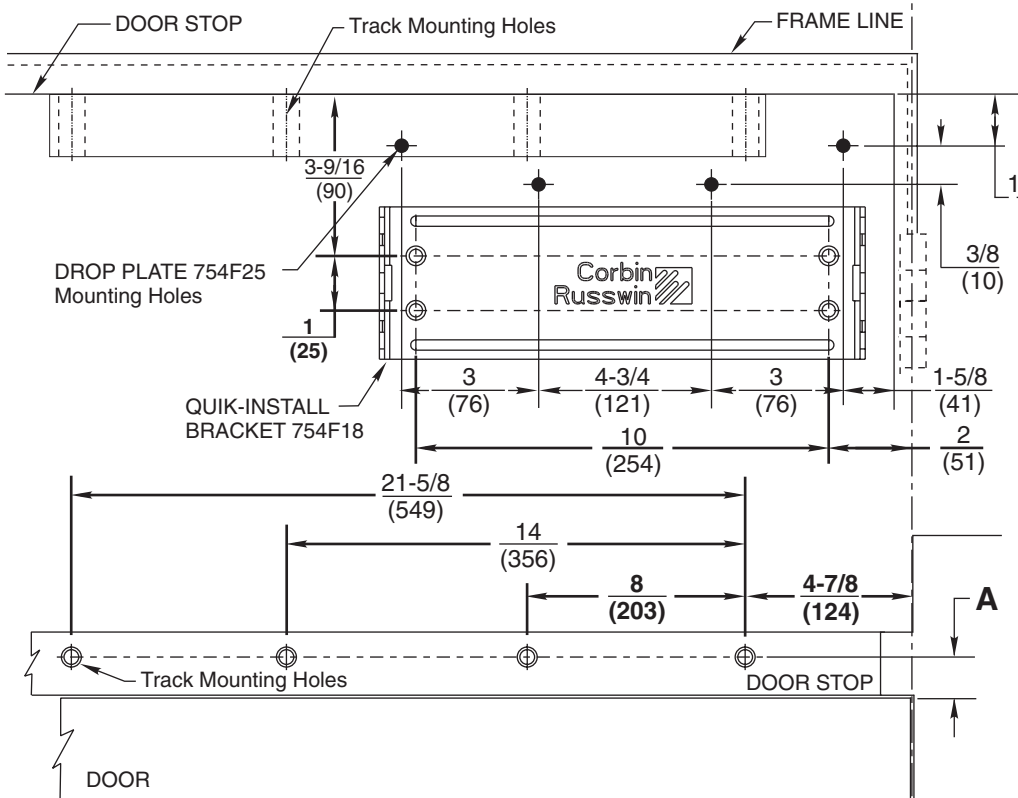

### MOUNTING SCREW SPECIFICATIONS ARM AND QUIK-INSTALL BRACKET

#12-14 self-drilling screw  
Type BSD. 1/8 (3) diameter  
pilot hole required for Wood  
Applications.

- OR -

Sex nuts, furnished  
when ordered

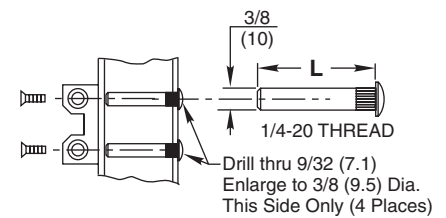

DOOR THICKNESS	SEX NUT LENGTH "L"
1-3/8 (35)	1-9/32 (33)
1-3/4 (44) & OVER	1-21/32 (42)

Mount the Track **CENTERED** on the Stop with the following minimum distances from the door side of the stop.

	A Min	Min Stop Width
With Drop Plate	1 (25)	1-3/4 (45)
Without Drop Plate	3/4 (19)	1-1/2 (38)

### NOTES:

- Check hand of door, see page 1.
- Right Hand Application Shown. Left Hand Opposite.
- Dimensions given in inches (mm). Do Not Scale Drawing.
- Closer must be installed in a true horizontal plane to ensure proper closer performance.
- Minimum stop width: See Dimension A on the chart to the right.
- Minimum top rail: Without drop plate 5-1/2 (140), With drop plate 2-1/2 (64).

## B Mount QUIK-INSTALL Bracket

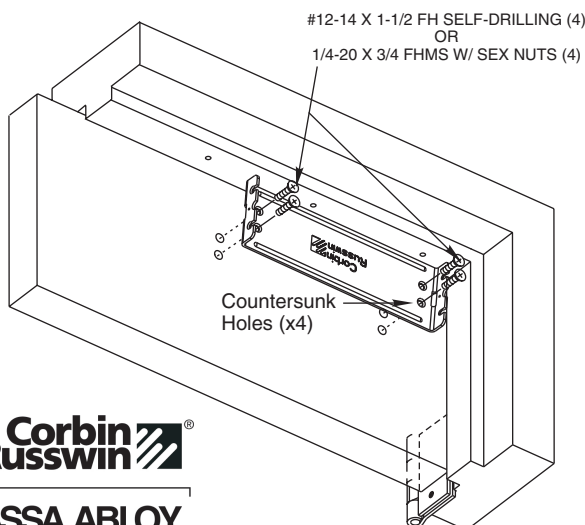

**Corbin  
Russwin**  
**ASSA ABLOY**

## C Mount Closer Body to QUIK-INSTALL Bracket

- Start the four mounting screws into the four closer mounting holes.
- Place the closer onto the QUIK-INSTALL bracket with the four mounting screws inserted into the four QUIK-INSTALL bracket slots.
- Tighten the four mounting screws to fasten the closer body to the QUIK-INSTALL bracket.

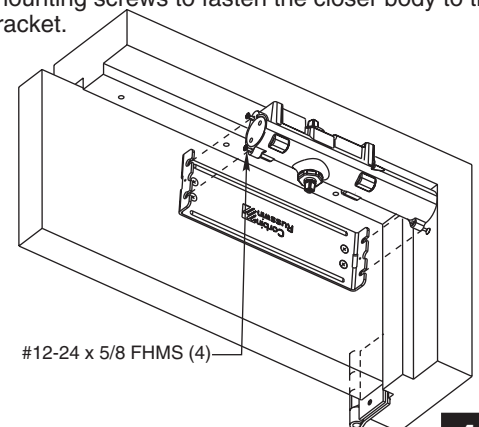

#12-24 x 5/8 FHMS (4)

# DC8240 Push Side Track Installation Instructions

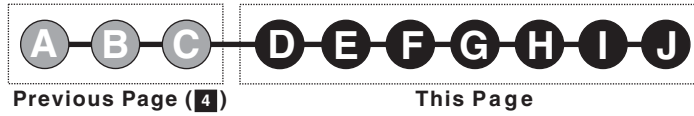

## D Attach Track to Frame

With spring buffer toward hinge edge of frame and open side facing down, fasten track assembly to frame.

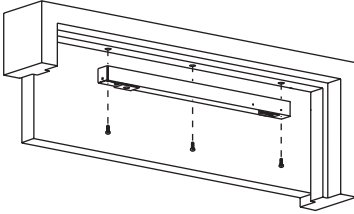

## E Adjust Arm to Shortest Length

Install 9/64" hex drive socket head screw from screw pack to the arm's shortest length as shown below.

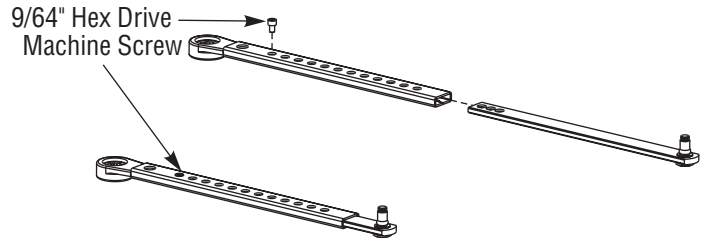

## F Place Slide Arm on Pinion Shaft

Place the slide arm and two washers on the pinion shaft, indexed as shown below. Secure the arm with the arm screw and washer as indicated.

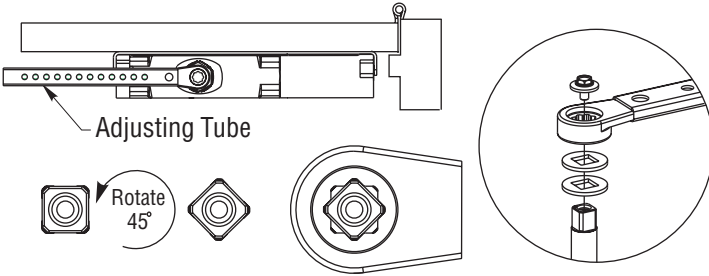

## G Insert Arm Stud into Slide Block

1) Insert the arm stud into the slide block in the track assembly. 2) Secure by pushing in on the retainer clip that extends from the slide block in the track, until it is flush with the slide block.

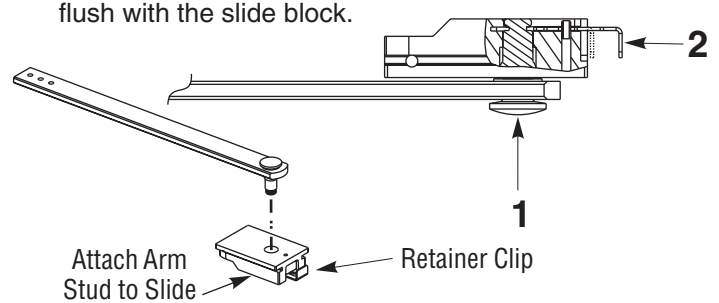

## H Adjusting Door Opening / Hold Open Angle

Open the door until the slider is against the cushioned stop or engaged in hold open (A1 Option only). Remove the 9/64" hex drive socket head screw from the arm. Open the door to the desired angle and install the hex-drive screw into the hole in the adjusting rod that is aligned with the hole in the adjusting tube.

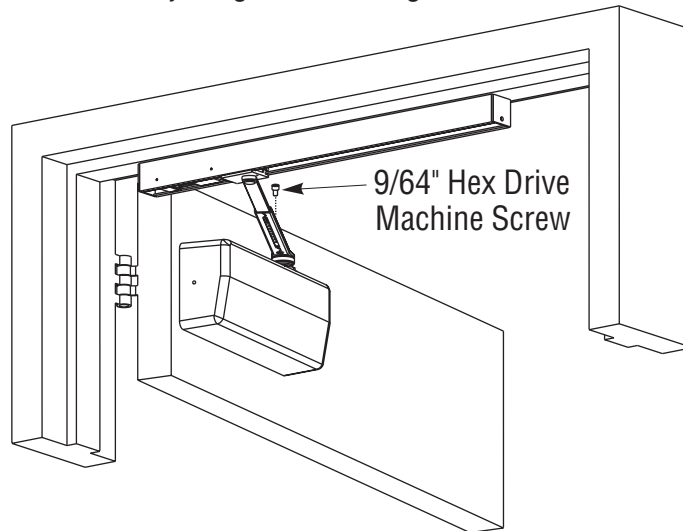

## I Adjust Closer: See Page 6.

## J ENGAGE/DISENGAGE Hold Open: (A1 Option Only) See Page 6.



ASSA ABLOY

# DC8230 & DC8240 Track Installation Instructions

## I ADJUST DOOR CLOSER

### Spring Power Adjustment

Locate spring power adjuster from Illustration below  
DC8200 Size 1 thru 6 Adjustment See Chart

Size of Door			Spring Power Adjustment No. Full Turns Clockwise	Equivalent Closer Size (Approx.)
Interior	Exterior In Swing	Exterior Out Swing		
2' 4" (712)	2' 6" (764)	—	2-7	3
2' 6" (764)	3' 0" (915)	—	7-11	4
3' 0" (915)	3' 6" (1067)	2' 6" (764)	11-15	5
3' 6" (1067)	4' 0" (1219)	3' 0" (915)	15-17	6

### DC8200 SPRING POWER ADJUSTMENT CHART

- All DC8200 closers are factory set at an approximate **Size 3**.
- Adjust closer as necessary for door size using this chart.
- Readjustment may be required to suit prevailing conditions.

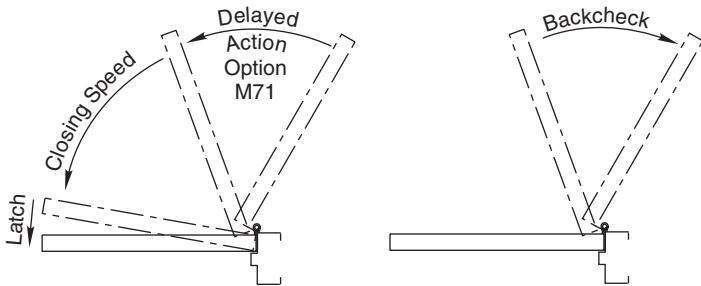
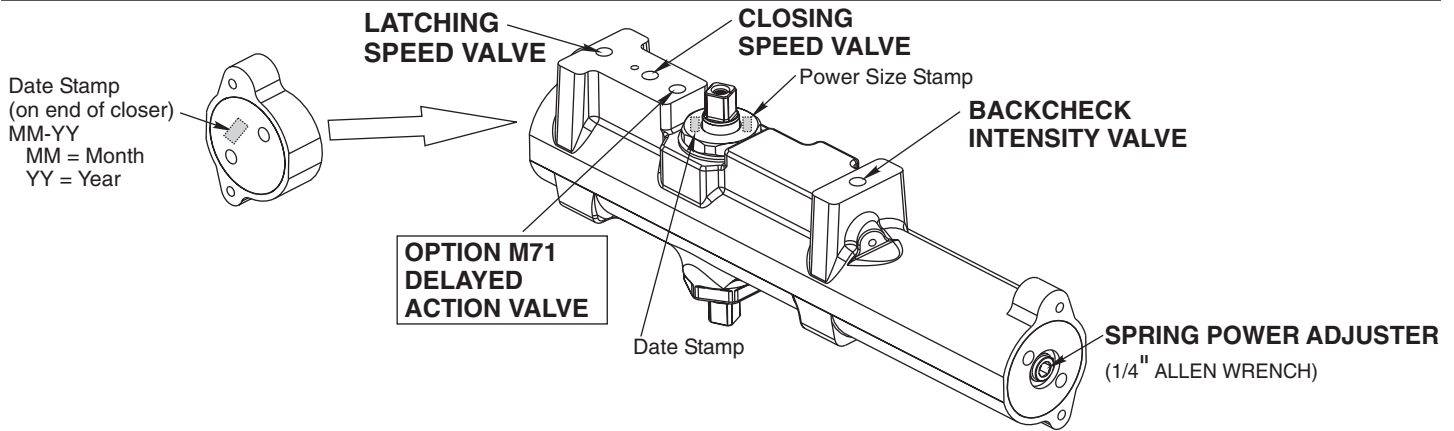

### Closing Speed Valve (1/8 Allen Wrench Provided)

To adjust speed of door closing from fully open to a position 2" to 5" from closed, turn Closing Speed Valve **CLOCKWISE** to SLOW closing, **COUNTER-CLOCKWISE** to SPEED closing.

### Latching Speed Valve (1/8 Allen Wrench Provided)

After closing speed has been obtained, turn latching speed valve **CLOCKWISE** to SLOW latching or **COUNTER-CLOCKWISE** to SPEED latching for last 2" to 5" of door travel.

**NOTE:** Set combination of CLOSING and LATCHING speeds to between 3 and 7 seconds Use of door by handicapped, elderly or small children may require even greater closing time.

### Delayed Action Valve (1/8 Allen Wrench Provided)

Turn valve **CLOCKWISE** to SLOW closing, **COUNTER-CLOCKWISE** to SPEED closing. Delayed action may be adjusted from 20 seconds to 90 seconds, depending on degree of door swing. Delay occurs at the beginning of the door closing cycle from fully open down to 70°, where the closing speed valve then begins its control.

### Backcheck Intensity Valve

Turn valve **COUNTER-CLOCKWISE** to reduce backcheck or **CLOCKWISE** to increase backcheck. (Backcheck should be set to give a soft cushioning action, not a sudden stop.)

### Installing Cover

- Slip cover over closer.
- Hold tightly against QUIK-INSTALL® Bracket surface.
- Secure on each side with 6-32 x 1/4" PBHMS screws.

Insert is removable.  
Place in unused opening.

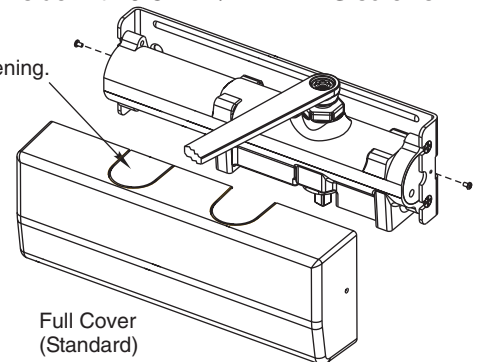

## J ENGAGE/DISENGAGE Hold Open (A1 Option Only)

Hold Open Models Only:  
Turn Screw 1/2 Revolution to Engage / Disengage Hold Open.

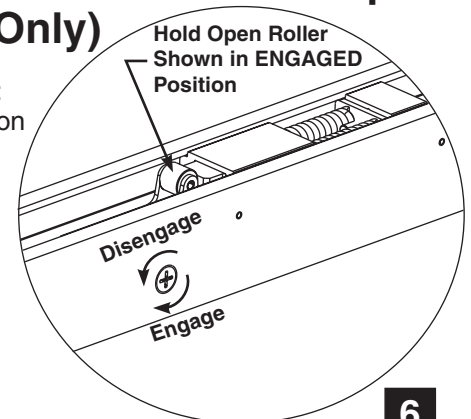

**Corbin  
Russwin**

**ASSA ABLOY**

80-9380-8006-152 Rev. 07-09

Copyright © 2006, 2009, Corbin Russwin, Inc., an ASSA ABLOY Group company. All rights reserved. Reproduction in whole or in part without the express written permission of Corbin Russwin, Inc. is prohibited.

ASSA ABLOY is the global leader in door opening solutions, dedicated to satisfying end-user needs for security, safety and convenience.