

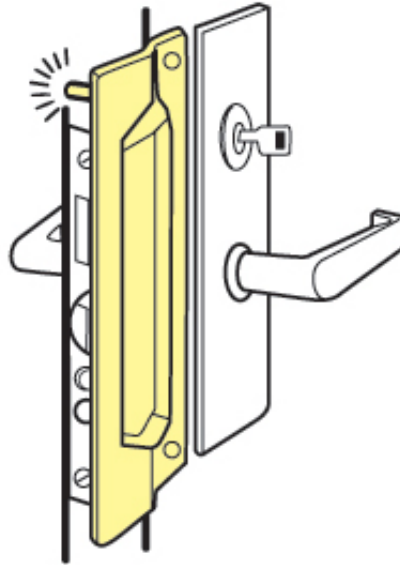

Latch Protector PMLP 111



Product Specifications

Number	PMLP 111
Dimensions	3" x 11"
Gauge	12 ga., .104
Material	Stainless Steel
Shelf pack	10
Features	Solid steel pin prevents spreading of door from frame, Pin is welded on back leaving no visible point of attack from outside, Furnished with carriage bolts, washers & acorn cap nuts
Finishes	630
Competitor part	340D, LG1, 320, ELP-250-1

